

CAVAWOOD

architectural products

project

date

type

● PLANT HANGER

Order Number	Arm length(s)
<input type="radio"/> PHS-18	18" (457mm) single arm
<input type="radio"/> PHS-24	24" (610mm) single arm
<input type="radio"/> PHT-218	18" (457mm) twin arms at 180°
<input type="radio"/> PHT-224	24" (610mm) twin arms at 180°

Total arm length is 2" (50mm) longer than arm length stated above. Maximum hanging weight is 75 pounds.

● COLOR

Order Number	Description
<input type="radio"/> SLVR	Silver with clear coat
<input type="radio"/> BRNZ	Architectural Bronze
<input type="radio"/> BLACK	Textured Black

* Custom colors based on the international RAL Color System are available with a lightly textured semi-gloss finish. Specify the color by the four digit RAL number. Example: RAL 8017

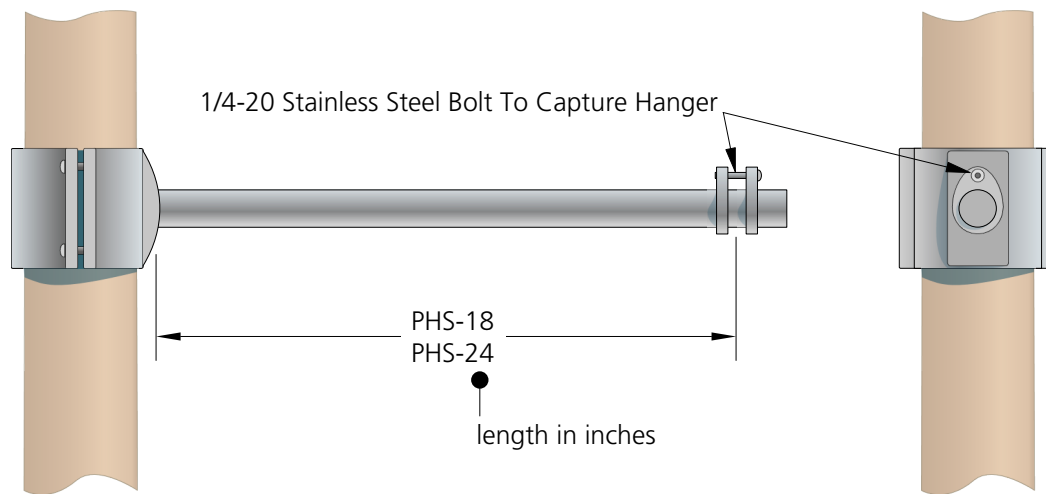

Plant Hanger Specification

Structure

The clam shell clamps to the pole shaft with four 5/16-18 stainless steel, button head bolts. The inside surfaces of the clam shells are lined with silicone pads to protect the pole and provide a tight, non slip fit. The clam shells are cast aluminum. The arm is 1.50" (150mm) diameter, .25" (6mm) wall tube. The two capture rings are .25" (6mm) with a 1/4-20 stainless steel bolt used to capture the hanger.

Finish

Polyester powder coat textured finish. Available in three standard colors or RAL colors. The exterior grade, UV-resistant finish provides excellent salt spray resistance according to ASTM B117 testing procedures.

Warranty

The product is warranted to be free from manufacturing defects for three years from the date of shipment.